

# GLÖTZL Baumeßtechnik

## LOAD CELL for PILE INSTRUMENTATION

Type: KLP .....

Art. No. 43.50

- Robust and simple system with small overall height
- Compact equipment, finally assembled
- Short installation time, small construction restraint
- Hydraulic principle, meas. system free selectable
- Can be equipped and retrofitted from manual measurement up to remote control
- Approved and successfully used system

### Description

The hydraulic load cell consists of a piston pad with two disks which are flexible by turned ring-dovetail grooves at the rims.

The 2 mm high pressure area of the pressure pad is filled with hydraulic oil and has an exactly defined area.

By this, a conversion of hydraulic pressure into load / charge is ensured.

The load cells have the advantage of a small overall height of 16 up to 25 mm, according to the load ranges.

### Application

The load cells are available in two models:

- Load cell for measurements at pile bottom
  - equipped with bottom frame for welding on microcellular rubber rim
  - Concreted tip
- Load cell for measurements at pile top
  - Flat construction for installation between pile top and fundamental plate

### Measurement of load cells can be done with:

- Manometer with direct reading of load
- Glötzl hydraulic compensation valve
- Electric pressure transducer, piezoelectric
- Electric vibrating wire transducer

For security of measuring value recording, normally an abundant sensor equipment is selected. It optionally consists of a hydraulic compensation valve with piezoelectric sensor or vibrating wire sensor.



### Figure:

Load cell with 1200 mm diameter at pile bottom, installed with microcellular rubber rim, welded-on bottom frame at pile basket and concreted tip

### Measuring task:

Measurement of pressure at pile top which resulted from loading, reduced by cover friction

The microcellular rubber rim is effecting the total loading over the load cell.

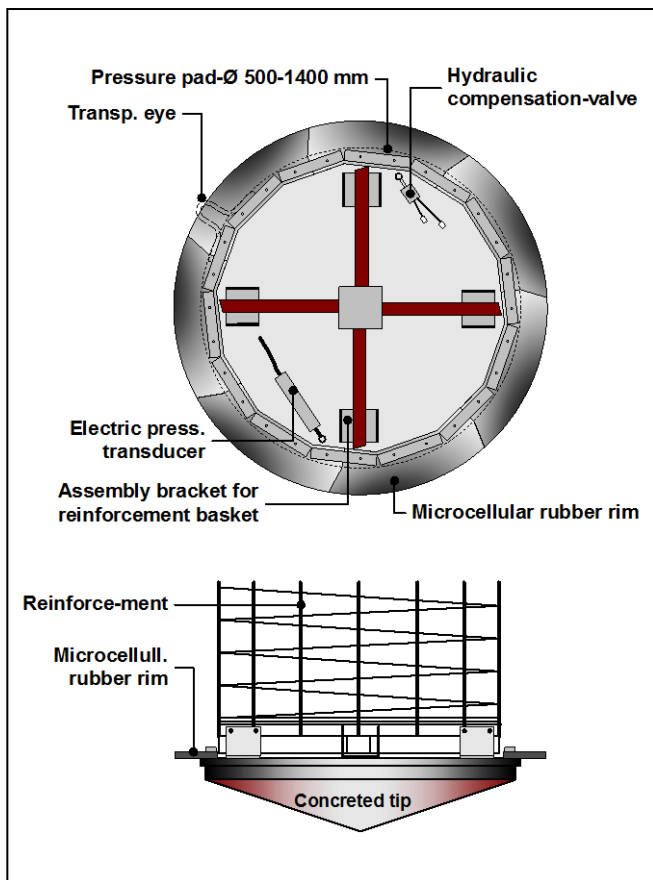
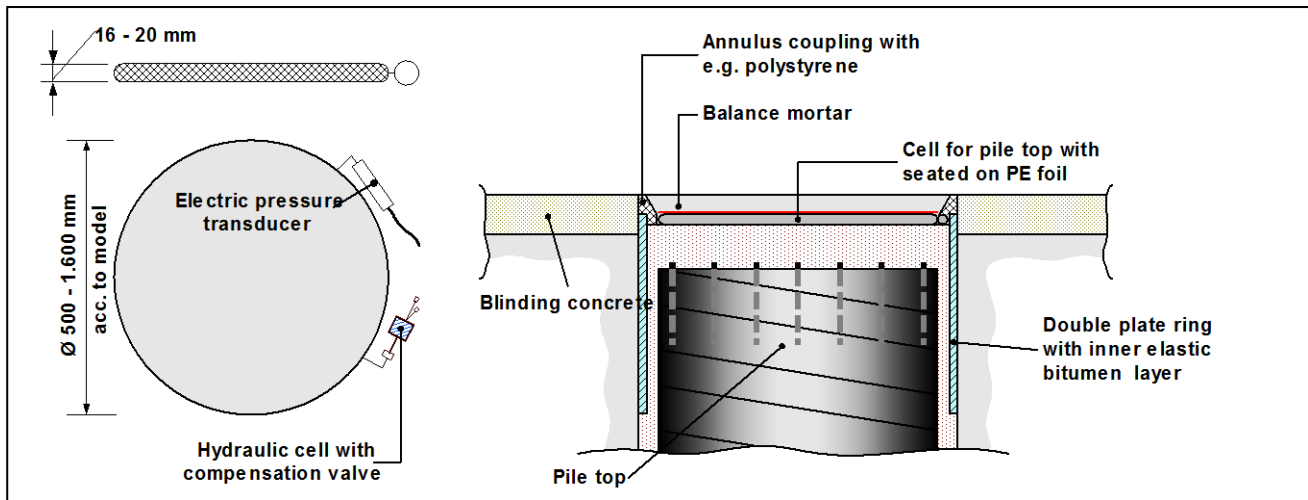

Fig.: Pile bottom cell, bottom side with concreted tip



Fig.: Pile bottom cell, upper side, with cell, assembly bracket and microcell. rubber

Art. No.:	Type	Pressure pad [mm] Ø	Pressure pad [mm] Höhe	Load range [MN]
43.50.1W.01	KLP	500	16	8.
43.50.1W.02	KLP	600	16	12
43.50.1W.03	KLP	800	16	20
43.50.1W.04	KLP	1000	16	30
43.50.1W.05	KLP	1200	18	45
43.50.1W.06	KLP	1400	18	60

Diameter and load range as above, however for pile bottom cell

43.50.2W.XX

Additional equipment for pile bottom cells:

43.50.61.XX	Microcellular rubber rim
43.50.62.XX	Assembly bracket for connection at reinforcement basket
43.50.63.XX	Concreted tip

Variants of meas. procedure:

Art. No.:	Abbrev.	Description
43.50.V1.XX	VHD	hydraulic compensation valve system Glötzl
43.50.V2.XX	AU	piezoelectric pressure transducer
43.50.V3.XX	VW	Vibrating wire transducer, frequency range 2.5 – 3.5 kHz
43.50.V4.XX	VM	Vibrating wire transducer, model Maihak/Glötzl, frequency range 700–1000 Hz
43.50.V5.XX	VHD/AU	abundant model VHD + AU

Further combinations of abundant models on request

Subject to technical alterations

**GLÖTZL** Gesellschaft für Baumeßtechnik mbH · Forlenweg 11 · 76287 Rheinstetten · Germany

☎ +49 (0)721 51 66 - 0 · 📠 +49 (0)721 51 66 - 30 · 🌐 <http://www.gloetzl.com> · 📧 [info@gloetzl.com](mailto:info@gloetzl.com)